

**JUMBO 42XL**

**VACUUM PACKAGING MACHINE**



\*optional with 2nd seal bar

**FEATURES**

- Standard with 1 seal bar (front): 420 mm
- Standard double seal (two wires). Optional without extra costs: Cut-off/Wide seal
- Seal bars easily removable for cleaning and maintenance purposes
- Pump capacity: 16 m<sup>3</sup>/h Busch vacuum pump
- Pump maintenance and cleaning program
- Machine cycle: 20-40 sec
- Standard Time control with a 1 program memory
- Deep drawn stainless steel vacuum chamber
- Stainless steel exterior and transparent lid
- Comes with insert plate for a faster cycle and product adjustment

**OPTIONS**

- 2nd seal bar (front-back)
- Sensor control

**ACCESSORIES**

- Inclined insert plate (for packing liquids)
- Food container adaptor
- Service kit for standard maintenance
- Trolley with shelves

**DESCRIPTION**

The robust, stainless steel Jumbo 42XL vacuum packaging machine is standard equipped with a Busch vacuum pump and Time control with a 1 program memory. This table-top model complies with CE standards.



Henkelman offers standard 3 year warranty

# VACUUM PACAGKING MACHINE JUMBO 42XL – SPECS

VACUUM PACKAGING MACHINE JUMBO 42XL – SPEC SHEET

## DIMENSIONS

In mm

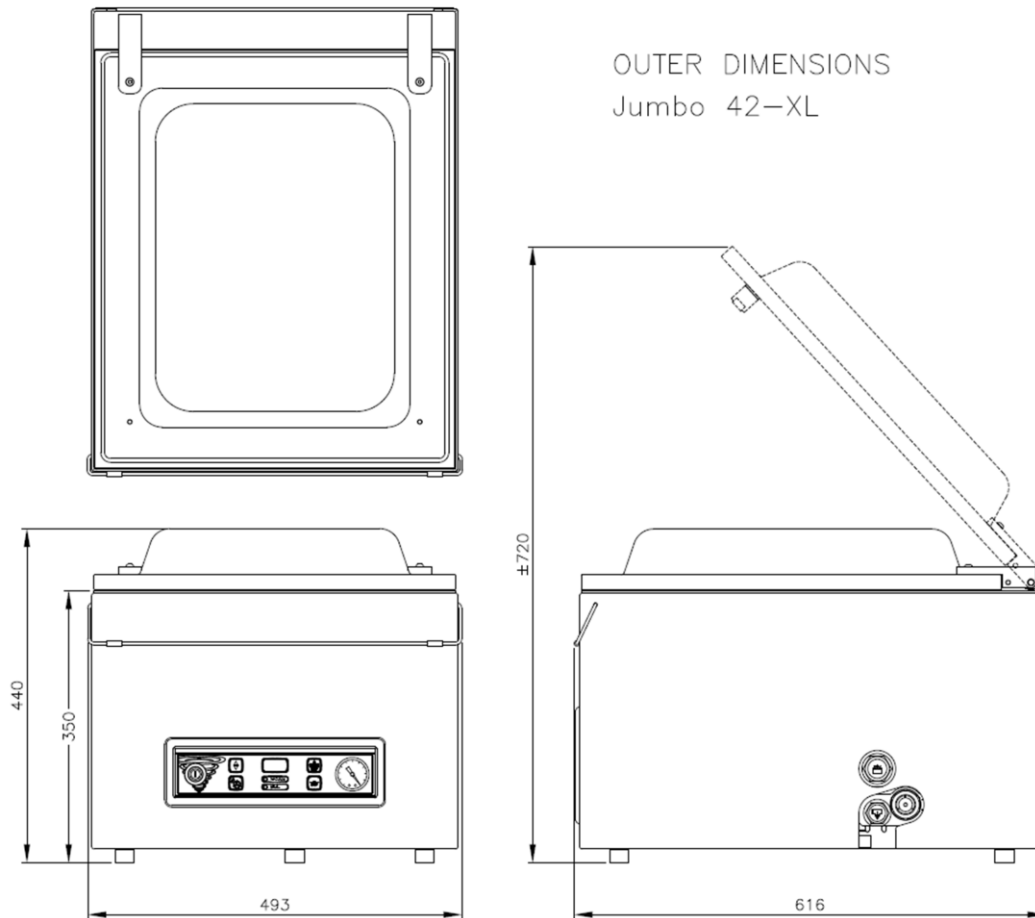

Model	Dimensions (mm)		Voltage* (Hz)	Pump capacity (m <sup>3</sup> /h)	Power (kW)	Weight (kg)
	Chamber (usable space) L x W x H	Machine L x W x H				
Jumbo 42XL	460 x 420 x 180	616 x 493 x 440	230V-1-50	16	0,55 kW	65

\* Other voltages available



HENKELMAN BV  
Titaniumlaan 10  
5221 CK 's-Hertogenbosch  
The Netherlands

**Sales support**  
P +31 73 621 36 71  
E [info@henkelman.com](mailto:info@henkelman.com)  
**Service/technical support**  
P +31 73 621 36 71  
E [service@henkelman.com](mailto:service@henkelman.com)